

John Deere Active Implement Guidance



OPERATOR'S MANUAL John Deere Active Implement Guidance OMPFP12957 ISSUE L2 (ENGLISH)

CALIFORNIA Proposition 65 Warning

Diesel engine exhaust and some of its constituents are known to the State of California to cause cancer, birth defects, and other reproductive harm.

If this product contains a gasoline engine:

⚠ WARNING

The engine exhaust from this product contains chemicals known to the State of California to cause cancer, birth defects or other reproductive harm.

The State of California requires the above two warnings.

Additional Proposition 65 Warnings can be found in this manual.

John Deere Ag Management Solutions

LITHO IN U.S.A.



Introduction

www.StellarSupport.com

NOTE: Product functionality may not be fully represented in this document due to product changes occurring after the time of printing. Read the latest Operator's Manual and Quick Reference Guide prior to operation. To obtain a copy, see your dealer or visit www.StellarSupport.com

OUO6050,0000FB1 -19-10AUG10-1/1

Foreword

WELCOME TO THE GreenStar™ System offered by John Deere.

READ THIS MANUAL carefully to learn how to operate and service your system correctly. Failure to do so could result in personal injury or equipment damage. This manual and safety signs on your machine may also be available in other languages. (See your John Deere dealer to order.)

THIS MANUAL SHOULD BE CONSIDERED a permanent part of your system and should remain with the system when you sell it.

MEASUREMENTS in this manual are given in both metric and customary U.S. unit equivalents. Use only correct replacement parts and fasteners. Metric and inch fasteners may require a specific metric or inch wrench.

RIGHT-HAND AND LEFT-HAND sides are determined by facing in the direction of forward travel.

WRITE PRODUCT IDENTIFICATION NUMBERS (P.I.N.) in the Specification or Identification Numbers section.

GreenStar is a trademark of Deere & Company

Accurately record all the numbers to help in tracing the components should they be stolen. Your dealer also needs these numbers when you order parts. File the identification numbers in a secure place off the machine.

WARRANTY is provided as part of John Deere's support program for customers who operate and maintain their equipment as described in this manual. The warranty is explained on the warranty certificate which you should have received from your dealer.

This warranty provides you the assurance that John Deere will back its products where defects appear within the warranty period. In some circumstances, John Deere also provides field improvements, often without charge to the customer, even if the product is out of warranty. Should the equipment be abused, or modified to change its performance beyond the original factory specifications, the warranty will become void and field improvements may be denied.

JS56696,0000A3E -19-14JUN11-1/1

Contents

	Page		Page
Safety			
Recognize Safety Information	05-1		
Understand Signal Words	05-1		
Follow Safety Instructions	05-1		
Practice Safe Maintenance	05-2		
Handle Electronic Components and Brackets Safely	05-2		
Avoid High-Pressure Fluids	05-3		
Operate Implement Automation Systems Safely	05-3		
Introduction			
Theory of Operation	10-1		
Activating Active Implement Guidance	10-2		
To Make Active Implement Guidance Operate ...	10-3		
Machine Compatibility	10-3		
Replacing Eproms	10-3		
System Components			
Monitor and Control System	15-1		
StarFire GPS Receiver	15-1		
GreenStar Display	15-3		
Application Controller 1100	15-4		
Wheel Angle Sensor	15-5		
Setup			
Startup Requirements	20-1		
Implement Receiver Lateral Offset	20-2		
SCV Control Assignments	20-3		
Implement Steering Calibration	20-4		
SCV Threshold Calibration	20-5		
External Valve Hydraulic Flow Adjustment	20-7		
Requirement to Engage	20-8		
External Valve	20-8		
Operation			
Basic Operation of Active Implement Guidance System	25-1		
Engaging Active Implement Guidance	25-2		
In-Field Adjustments/Tuning	25-4		
Follow Mode	25-5		
Disabling Active Implement Guidance	25-6		
Disconnecting Active Implement Guidance			
Disconnecting the Active Implement Guidance System	30-1		
Troubleshooting			
Troubleshooting — Active Implement Guidance System	35-1		
Troubleshooting — Machine	35-2		
Troubleshooting — Active Implement Guidance External Valve	35-3		
Service			
Active Implement Guidance System	40-1		
Machine	40-1		
EC Declaration of Conformity	40-1		

Original Instructions. All information, illustrations and specifications in this manual are based on the latest information available at the time of publication. The right is reserved to make changes at any time without notice.

COPYRIGHT © 2012
DEERE & COMPANY
Moline, Illinois
All rights reserved.
A John Deere ILLUSTRATION © Manual

Safety

Recognize Safety Information

This is a safety-alert symbol. When you see this symbol on your machine or in this manual, be alert to the potential for personal injury.

Follow recommended precautions and safe operating practices.



DX,ALERT -19-29SEP98-1/1

TS1389 —UN—07DEC88

Understand Signal Words

A signal word—DANGER, WARNING, or CAUTION—is used with the safety-alert symbol. DANGER identifies the most serious hazards.

DANGER or WARNING safety signs are located near specific hazards. General precautions are listed on CAUTION safety signs. CAUTION also calls attention to safety messages in this manual.



▲ WARNING

▲ CAUTION

DX,SIGNAL -19-03MAR93-1/1

TS187 —19—30SEP88

Follow Safety Instructions

Carefully read all safety messages in this manual and on your machine safety signs. Keep safety signs in good condition. Replace missing or damaged safety signs. Be sure new equipment components and repair parts include the current safety signs. Replacement safety signs are available from your John Deere dealer.

There can be additional safety information contained on parts and components sourced from suppliers that is not reproduced in this operator's manual.

Learn how to operate the machine and how to use controls properly. Do not let anyone operate without instruction.

Keep your machine in proper working condition. Unauthorized modifications to the machine may impair the function and/or safety and affect machine life.



If you do not understand any part of this manual and need assistance, contact your John Deere dealer.

DX,READ -19-16JUN09-1/1

TS201 —UN—23AUG88

Practice Safe Maintenance

Understand service procedure before doing work. Keep area clean and dry.

Never lubricate, service, or adjust machine while it is moving. Keep hands, feet, and clothing from power-driven parts. Disengage all power and operate controls to relieve pressure. Lower equipment to the ground. Stop the engine. Remove the key. Allow machine to cool.

Securely support any machine elements that must be raised for service work.

Keep all parts in good condition and properly installed. Fix damage immediately. Replace worn or broken parts. Remove any buildup of grease, oil, or debris.

On self-propelled equipment, disconnect battery ground cable (-) before making adjustments on electrical systems or welding on machine.

On towed implements, disconnect wiring harnesses from tractor before servicing electrical system components or welding on machine.



TS218 —UN—23AUG88

DX,SERV -19-17FEB99-1/1

Handle Electronic Components and Brackets Safely

Falling while installing or removing electronic components mounted on equipment can cause serious injury. Use a ladder or platform to easily reach each mounting location. Use sturdy and secure footholds and handholds. Do not install or remove components in wet or icy conditions.

If installing or servicing a RTK base station on a tower or other tall structure, use a certified climber.

If installing or servicing a global positioning receiver mast used on an implement, use proper lifting techniques and wear proper protective equipment. The mast is heavy and can be awkward to handle. Two people are required when mounting locations are not accessible from the ground or from a service platform.



TS249 —UN—23AUG88

DX,WW,RECEIVER -19-24AUG10-1/1

Avoid High-Pressure Fluids

Inspect hydraulic hoses periodically – at least once per year – for leakage, kinking, cuts, cracks, abrasion, blisters, corrosion, exposed wire braid or any other signs of wear or damage.

Replace worn or damaged hose assemblies immediately with John Deere approved replacement parts.

Escaping fluid under pressure can penetrate the skin causing serious injury.

Avoid the hazard by relieving pressure before disconnecting hydraulic or other lines. Tighten all connections before applying pressure.

Search for leaks with a piece of cardboard. Protect hands and body from high-pressure fluids.

If an accident occurs, see a doctor immediately. Any fluid injected into the skin must be surgically removed within a few hours or gangrene may result. Doctors unfamiliar

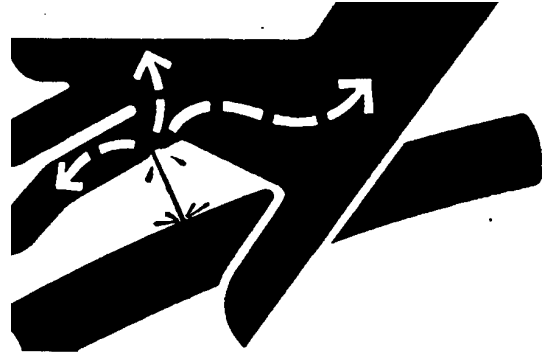

with this type of injury should reference a knowledgeable medical source. Such information is available in English from Deere & Company Medical Department in Moline, Illinois, U.S.A., by calling 1-800-822-8262 or +1 309-748-5636.

DX,FLUID -19-12OCT11-1/1

X9811—UN—23AUG88

Operate Implement Automation Systems Safely

Do not use implement automation systems on roadways. Always turn off (disable) implement automation systems before entering a roadway. Do not attempt to turn on (activate) an implement automation system while transporting on a roadway.

Implement automation systems are intended to aid the operator in performing field operations more efficiently. The operator is always responsible for the machine path.

Implement automation systems include any application that automates implement movement. This includes, but may not be limited to, iGrade and Active Implement Guidance.

To prevent injury to the operator and bystanders:

- Verify machine, Implement, and automation systems are set up correctly.
- Remain alert and pay attention to surrounding environment.
- Take control of machine, when necessary, to avoid field hazards, bystanders, equipment, or other obstacles.
- Stop operation if poor visibility conditions impair your ability to operate machine or identify people or obstacles in machine's path.



CF86321.0000366 -19-26JUN12-1/1

PC13793—UN—25MAY11

Introduction

Theory of Operation

Active Implement Guidance is a system which allows a symmetric implement and tractor to be independently steered onto a common track. It does this with a StarFire™ GPS receiver mounted on both the tractor and implement. By knowing the location of the tractor and implement, Active Implement Guidance enables operators to automate the steering along a preset line. This automation allows operators to focus more on the equipment and task at hand and less on the mechanics of operating the machine.

Active Implement Guidance can be used for pull-type and integral implements.

NOTE: Active Implement Guidance performance is limited to the ability of the steering system used. Use the proper steering system for your conditions.

StarFire is a trademark of Deere & Company

Active Implement Guidance will operate in reverse for 45 seconds. After 45 seconds, AutoTrac and Active Implement Guidance will both disengage, removing their control of tractor and implement

IMPORTANT: Performance of reverse operation is limited by the characteristics of each implement steering system. In most cases, reverse operation is not recommended at this time. To avoid performance issues or possible damage to machines, know and understand the limitations of your system before attempting to use Active Implement Guidance in reverse.

DK01672,0000164 -19-08AUG11-1/1

Activating Active Implement Guidance

To run Active Implement Guidance on the Application Controller 1100 a 26 digit activation code is required.

1. Visit www.StellarSupport.com or call 1-888-953-3373
2. Using the controller serial number and the COMAR order number, a 26 digit activation code will be generated.
3. On the display, select APPLICATION CONTROLLER 1100 from the main menu.
4. Select SETUP softkey.
5. Select ACTIVATION ENTRY (A) button.
6. Enter 26 digit code (B).

NOTE: I/O Voltages are for diagnostic use only.

A—Application Controller C—Activation Entry
 B—Setup D—Activation

PC14866 —UN—17APR12



Application Controller 1100 Softkey

PC13531 —UN—03MAY11

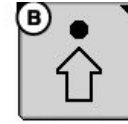

Setup SoftKey

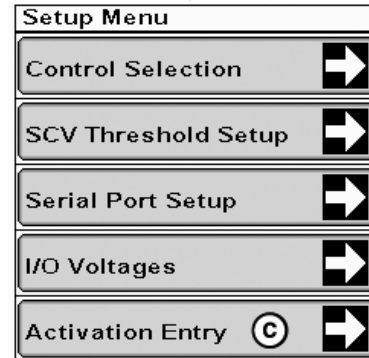

Setup Menu

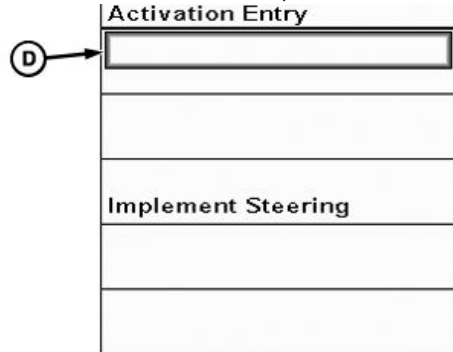

Activation

BA31779,00003F4 -19-27APR12-1/1

PC13490 —UN—03MAY11

PC13532 —UN—02MAY11

To Make Active Implement Guidance Operate

Active Implement Guidance Functional Requirements:

Hardware:

- GreenStar 2 1800, GreenStar 2 2600, GreenStar 3 2630 display, or GreenStar 3 CommandCenter console mounted in machine.
- John Deere StarFire GPS receiver mounted on tractor.
- John Deere StarFire GPS receiver and bracket mounted on implement.
- Application Controller 1100 with Active Implement Guidance activation installed on tractor.
- Implement-mounted steering angle sensor.

NOTE: Wheel angle Sensor is not required for implement shifting applications.

- Hydraulic steering mechanism mounted on implement.
- Various harnesses associated with power supply, controller integration, sensor communication, and steering control.

Software:

- Active Implement Guidance operation requires both receivers to have an RTK signal level, unless you are using Shared Signal.

- Updated StarFire receiver software (Active Implement Guidance only).

NOTE: When updating the receiver software, only one receiver can be connected to the CAN bus.

It is not possible to reprogram an implement receiver using an Original GreenStar Display.

- Machine receiver setup including TCM calibration.
- Implement receiver setup including TCM calibration.
- AutoTrac activation on display (not required to run system manually).
- AutoTrac and Active Implement Guidance setup complete (incomplete AutoTrac setup would prevent operator from activating guidance).

NOTE: Currently, Active Implement Guidance supports the update of SF2 corrections at the machine with the use of Shared Signal. See Shared Signal section for more information.

BA31779,00003F6 -19-02MAY12-1/1

Machine Compatibility

NOTE: For a full list of approved and compatible non John Deere tractors for use with John Deere Active Implement Guidance and the External Valve, visit www.stellarsupport.com.

The guidance portion of Active Implement Guidance is compatible on machines installed with Integrated AutoTrac, AutoTrac Universal or AutoTrac Controller.

The Active Implement Guidance external valve kit will add a hydraulic control to tractors that may not come with factory installed hydraulic controls.

BA31779,00003F7 -19-12APR12-1/1

Replacing Eproms

On some early models of 8000/9000 Series tractors it will be necessary to replace or upgrade the tractor hydraulic controller.

Contact your John Deere dealer for assistance with early model machines.

NOTE: To replace eproms in your tractor control unit, making it compatible with Active Implement Guidance, see your John Deere dealer.

8020/9020 Series tractors are factory compatible with Active Implement Guidance.

DK01672,00000D3 -19-02JUN11-1/1

System Components

Monitor and Control System

Because the monitor and control systems are an integral part of the machine, operations involving displays and electronic controllers are shown throughout the manual, in their respective sections.

Monitor portion of the system: takes signals from the wheel angle sensors along with relevant implement GPS information and displays the activity on the cab-mounted console. The active display informs the operator of

machine activities before they can be seen from the operator seat.

Control portion of the system: used to steer implement along the desired guidance line. Control system continually adjusts the implement steering cylinder to maintain zero off-track error. A continuous system adjustment compensates for external disturbances to the system that would normally cause implement to track off the desired path.

DK01672,00000CA -19-02JUN11-1/1

StarFire GPS Receiver

Active Implement Guidance requires two GPS receivers for operation.

- One John Deere StarFire GPS receiver must be mounted and operating on the tractor with a second receiver located on the implement.
- Both receivers must use an RTK signal level unless utilizing Shared Signal.

NOTE: For optimal performance, both receivers need to be the same model.

For Shared Signal both receivers must be StarFire 3000.

Shared Signal will operate at SF2 correctional signal with Active Implement Guidance.

Active Implement Guidance will operate with SF2 corrections when utilizing Shared Signal.



StarFire Receiver

- Implement receiver should not be mounted higher than 4.0 m (13.1 ft.) above ground level.
- Implement receiver must be connected to tractor's implement CAN bus through ISO connector.

PC13406 —UN—20APR11

Continued on next page

BA31779,00003FB -19-13APR12-1/3

Shared Signal

NOTE: Shared Signal will engage automatically, it is not possible to manually engage or disengage Shared Signal.

Shared Signal allows Active Implement Guidance to share the correction signal from the machine receiver to the implement receiver.

Shared Signal operation will automatically link and operate with Active Implement Guidance when the following requirements are met:

- StarFire 3000 receivers on machine and implement.
- GS3 2630 display.
- SF2 or RTK activation on machine receiver.
- SF1, SF2 or RTK on the implement receiver.
- Latest software updates on display, receiver and application controller.

	Implement RTK	Implement SF2	Implement SF1
Machine RTK	+/- 2"	+/- 2"	+/- 2"
Machine SF2	+/- 3-5"	+/- 3-5"	+/- 3-5"

To verify receivers are linked you can check the implement receiver page (A), or on the guidance view page (B), the link symbol will be displayed.

A—Linked receiver implement **B**—Linked guidance view page

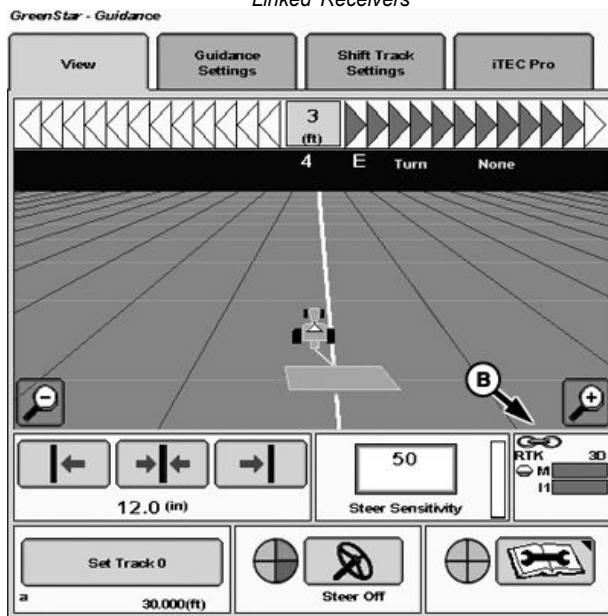
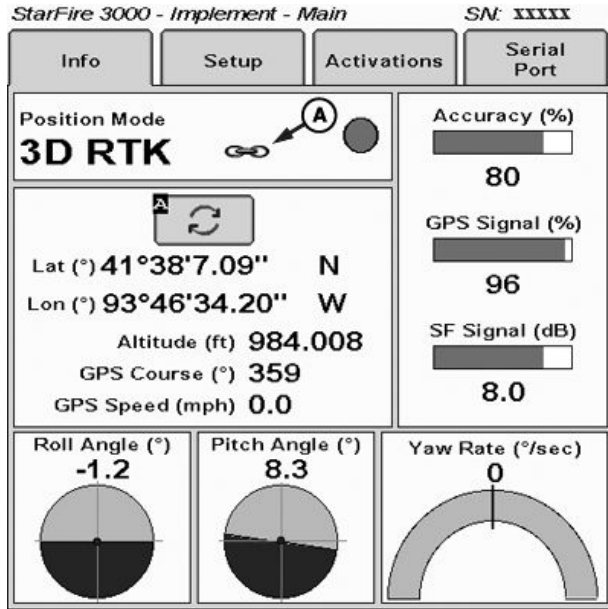

Linked guidance view page

Continued on next page

BA31779,00003FB -19-13APR12-2/3

PC13797—UN—02JUN11

PC13800—UN—02JUN11

Shared Signal automatically uses the machine correction signal. It is recommended that the higher correction signal be on the machine. If correction signal is higher on the implement the receiver accuracy warning will display.

NOTE: Accuracy warning does not disable Shared Signal.



Accuracy warning

BA31779,00003FB -19-13APR12-3/3

PC13798 —UN—02JUN11

GreenStar Display

Operator is informed of machine activity by observing display screen.

- Machine functions are selected or turned ON/OFF using touchscreen display or display controls.
- Display can be set to English or Metric units of measure.
- Operator entries must be made in same units of measure as display readout.
- Tractor Radar setting, units of measure and language selection are stored within display console.

NOTE: If new or different display console is used with machine, tractor radar setting must be retrieved from old display and manually entered into new display, or recalibrated and stored.

Units of measure and language selection must be reset on new display if different than factory defaults.

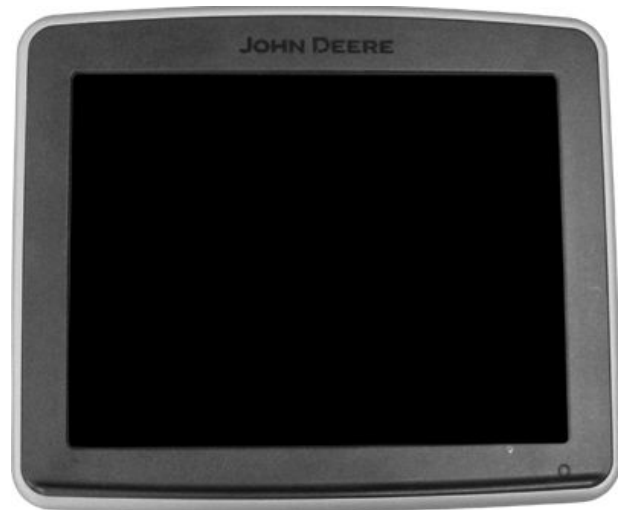

2630 Display

DK01672,00000CC -19-02JUN11-1/1

PC13407 —UN—20APR11

Application Controller 1100

The Application Controller 1100 (A) is located on rear of tractor, under cab rear cover.

NOTE: Controller location and alignment may differ for each model of tractor. Picture is for general reference only.

Reference the Application Controller 1100 / External Valve Installation Instructions for installation procedure.

The Application Controller 1100 contains:

- *Display Software* - used by the cab-mounted console
- *Microprocessor* - uses wheel angle sensor signals to control valve drivers.
- *Non-volatile Memory* - factory defaults and operator entered settings are stored here

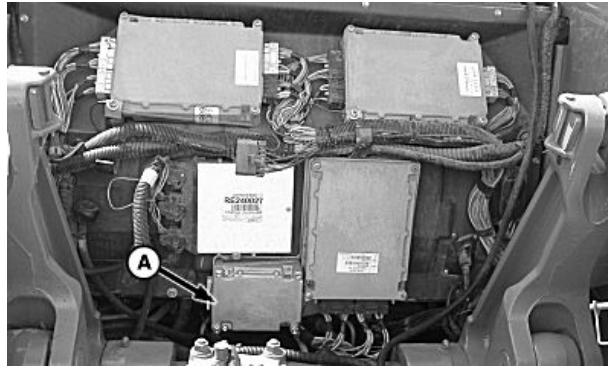

A—Controller

PC12186—UN—07OCT09

BA31779,00003F5 -19-02MAY12-1/1

Wheel Angle Sensor

At an indicative location for the implement steering system, a potentiometer (A) or a hall effect sensor (B) is used as a wheel angle sensor.

As the steering control cylinder extends or retracts, the feedback signal from the potentiometer changes to reflect the position of the implement steering mechanism. This signal is used as an input to control wheel angle, and feedback for tracking and accumulated sensitivities which are used to fine tune steering aggression.

NOTE: Some implement steering devices have a wheel sensor incorporated into the equipment.

Wheel angle sensor must be mounted and calibrated so its range of motion is aligned and symmetrical. Failure to properly mount sensor will result in poor performance. Refer to sensor installation instructions for proper procedure.

Verify hydraulic and mechanical steering linkage is properly adjusted per manufacturer's specifications. Refer to manufacturer's Operators Manual for your specific steering system.

A—Potentiometer

B—Hall Effect Sensor

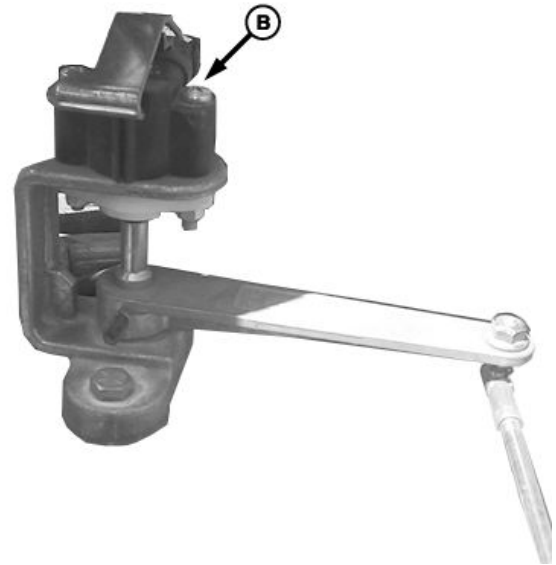
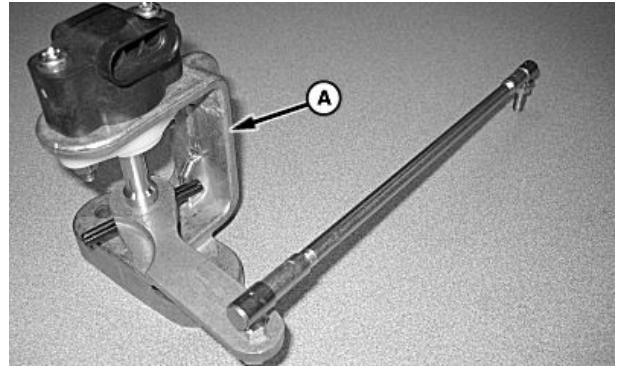

Hall Effect Sensor

PC12344—UN—19OCT09

PC12189—UN—14OCT09

PC13565—UN—03MAY11

DK01672,00000CE -19-02JUN11-1/1

Setup

Startup Requirements

PC14926 —UN—27APR12

- StarFire RTK receivers installed and functioning on machine and implement.
- Active Implement Guidance hardware installation complete.

NOTE: Shared Signal requires a StarFire 3000 receiver on machine and implement.

- SF2 or RTK Activation on machine receiver.
- SF1, SF2 or RTK on the implement receiver.
- Updated to latest StarFire Receiver software and Implement Steering active on the Application Controller.



Application Controller 1100 Softkey

- Machine receiver TCM calibration complete.
- Implement receiver setup (including offsets) and TCM calibration complete.
- AutoTrac setup complete and activated on display.

BA31779,00003FC -19-27APR12-1/1

PC13072 —UN—16NOV10

Implement Receiver Lateral Offset

On equipment where the implement receiver cannot be mounted in the center line of the implement, a Lateral Offset can be entered to account for the shifted location.

1. Select MAIN softkey.
2. Select Implement Steer Setup (A).
3. Select Implement GPS Offset (B)
4. Select offset direction by choosing either POSITION SHIFTED RIGHT or POSITION SHIFTED LEFT from the drop-down (C).
5. Enter the distance from the receiver to the center line of the implement in the LEFT/RIGHT SHIFT box (D)

A—Main Menu C—Position Shifted
 B—Implement Steer Setup D—Left/Right Shift



Application Controller Main Softkey

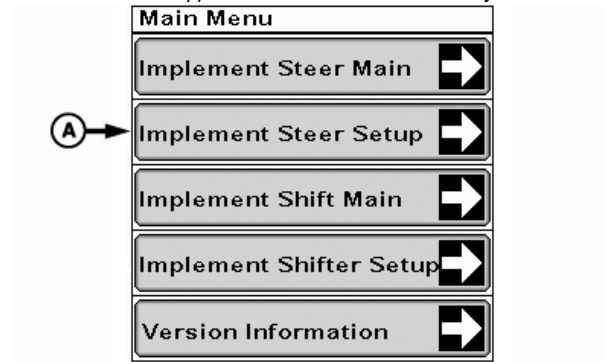

Main Menu



Implement Steer Setup

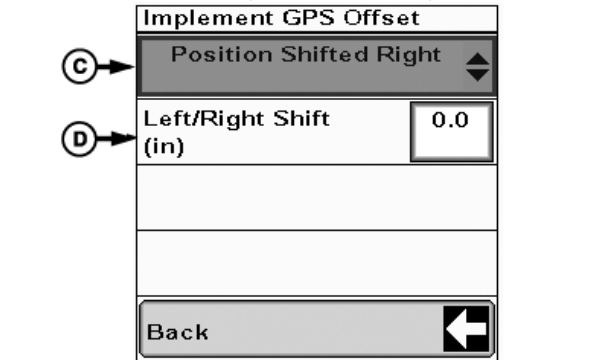

GPS Offset

PC13491 —UN—03MAY11

PC13539 —UN—03MAY11

PC13492 —UN—03MAY11

DK01672.00000D9 -19-03JUN11-1/1

SCV Control Assignments

NOTE: For ease of instruction, this manual will use SCV III for the Active Implement Guidance system. Operator may choose to use SCV I if preferred.

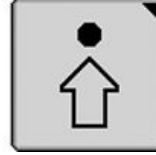

Setup Softkey

Allocate Control Type and GPS to SCV III:

1. Select SETUP softkey
2. Select CONTROL SELECTION (A).
3. Under SCV3 Control Type, select *Implement Steering* from drop-down list (B).
4. Cycle machine power
5. SCV Control allocation is now complete. Select BACK (C).

NOTE: If implement steers away from guidance line, hydraulic hoses to steering cylinder may be hooked up in reverse (see TROUBLESHOOTING section in this manual).

IMPORTANT: SCV control type selection must match the connection at the implement feedback sensor harness.

- A—CONTROL SELECTION Button C—BACK Button
 B—SCV Selection Drop Down

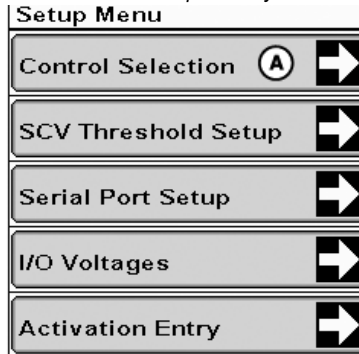

Control Selection

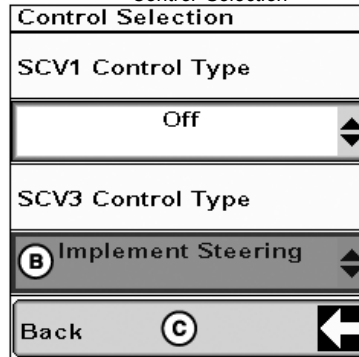

SCV Control Selection

PC13493 —UN—03MAY11

PC13497 —UN—03MAY11

PC13072 —UN—16NOV10

Implement Steering Calibration

NOTE: Implement Steering Calibration is not needed when operating implement shifting.

Once SCV Control and GPS has been allocated, additional PAGES become available for Active Implement Guidance setup.

CAUTION: Implement will move during calibration. Verify all people and obstructions are clear of immediate area during all procedures. Read and follow **OPERATE IMPLEMENT AUTOMATION SYSTEMS SAFELY** in SAFETY section prior to performing calibration.

Calibrate implement wheel steering:

1. Select MAIN softkey
2. Select IMPLEMENT STEER SETUP (A).

NOTE: The first two lines of this page are reserved for SCV1. The next two lines are reserved for SCV3.

Depending on steering system it may be best to drive forward slowly during wheel angle sensor calibration.

3. Select Wheel Angle Setup (B)
4. Manually move steered axle to the steered right limit and select SET MAX RIGHT POSITION (C).
5. Manually move steered axle to the steered left limit and select SET MAX LEFT POSITION (D).
6. Manually move steered axle to center position and select SET CENTER POSITION (E).

IMPORTANT: Center position setting is critical to accurate line acquisition and operation. Driving machine and implement forward before setting position may be required for proper calibration.

NOTE: Desired voltage range from full left limit to right limit is 0.5 - 4.5 volts. Voltage when centered should be near 2.5 volts.

If voltage difference from either left to center or right to center movement totals less than 1 volt, wheel angle sensor may need to be repositioned to increase range of motion.

Center Calibration Position Verification

To verify Center Position calibration is set correctly, setup and drive a straight track. When the error reads zero select Set Center Position (E) to verify the center position is set correctly.

Implement steering calibration is now complete.



Application Controller Main Softkey

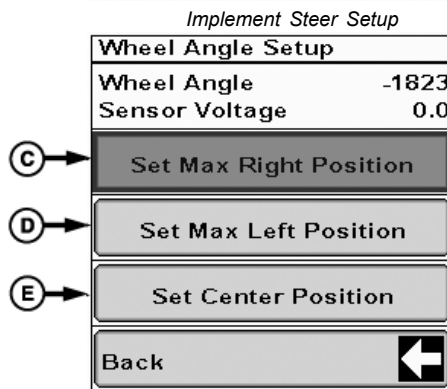
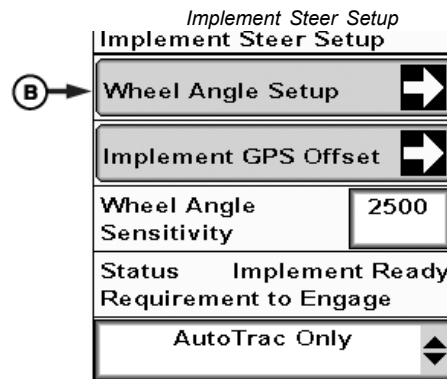
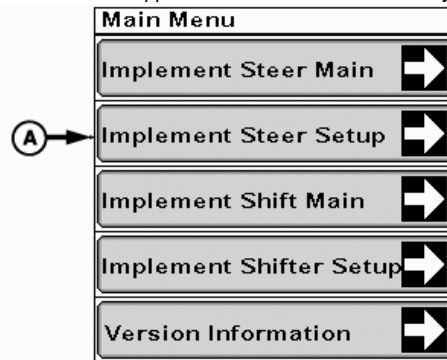

Wheel Angle Setup

- A—IMPLEMENT STEER SETUP Button
- B—Wheel Angle Setup Button
- C—SET MAX RIGHT POSITION Button
- D—SET MAX LEFT POSITION Button
- E—SET CENTER POSITION Button

PC13494 —UN—03MAY11

PC13536 —UN—03MAY11

PC13495 —UN—03MAY11

CF86321,000037D -19-31MAY11-1/1

SCV Threshold Calibration

PC12961 —UN—29AUG11

NOTE: SCV Threshold Calibration is not performed with external valve connection. To adjust hydraulic flow to the external valve refer to External Valve Hydraulic Flow Adjustment section of this operator manual.

CAUTION: To avoid serious injury, keep area around equipment clear. This procedure requires machine to move forward.

Implement will move during calibration. Read and follow **OPERATE IMPLEMENT AUTOMATION SYSTEMS SAFELY** in **SAFETY** section prior to performing calibration.

Each time Active Implement Guidance is installed on a different tractor, an SCV Threshold Calibration should be performed. Without SCV Threshold Calibration, the steering mechanism may steer significantly faster in one direction, under steer, over steer, or not perform as expected due to hydraulic limitations. These factors will make it difficult for the controller to maintain an off-track error of 0.

*NOTE: To calibrate the SCV Threshold, the machine must be slowly moving forward (greater than 0.5 kph /0.3mph) with selected SCV (SCV I or III) detented to "AC" or "AUTO", as displayed by SCV indicators. The implement **does not** need to be in the lowered (working) position for calibration.*

*If machine is not moving faster than 0.5 kph (0.3mph), SCV control **will not** produce hydraulic flow.*

Calibrate SCV Thresholds

1. Select SETUP softkey.

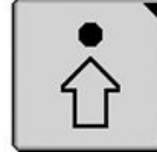

GreenStar Toolbox Setup Softkey

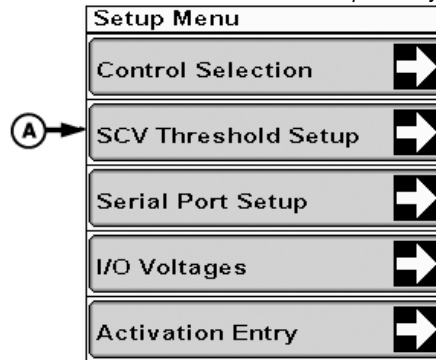

SCV Threshold Setup

A—SCV THRESHOLD SETUP Button

2. Select SCV THRESHOLD SETUP (A).

PC13496 —UN—03MAY11

Continued on next page

BA31779.00003FE -19-13APR12-1/2

3. Select the correct SCV (B) from the drop-down for the THRESHOLD SETUP
4. Select VALVE TEST menu button (C) and VALVE TEST EXTEND ON (D) from drop-down menu.
5. Adjust the EXTEND THRESHOLD Value (E) to lowest possible setting that still produces a steady, consistent motion.
 - If Sensor Voltage (F) does not change significantly, the Extend Threshold value must be increased.
 - If Sensor Voltage moves quickly or erratically, the Extend Threshold value must be decreased.
 - Repeat procedure as required to obtain a smooth, constant change in sensor voltage.

NOTE: Some implements may require sensor to be fully retracted to increase range of extend motion.

6. Select VALVE TEST menu button (C) and VALVE TEST RETRACT ON (G) from drop-down menu.
7. Repeat adjustment procedures used in Valve Test Extend calibration.

NOTE: Sensor Voltage will move in opposite direction of Valve Test Extend procedure.

8. Select Valve Test Off when finished.

Once constant movement is detected at wheel angle, threshold is set properly. Wheel angle should now cycle left to right in an equal and constant manner.

Tractor hydraulic flow may need increased or decreased on tractor Right-Hand Display or on Command Center to produce adequate hydraulic flow to implement steering system. SCV threshold setup should be repeated after hydraulic flow is adjusted. Adjusting threshold down should only be necessary on small cylinder or low flow mechanisms.

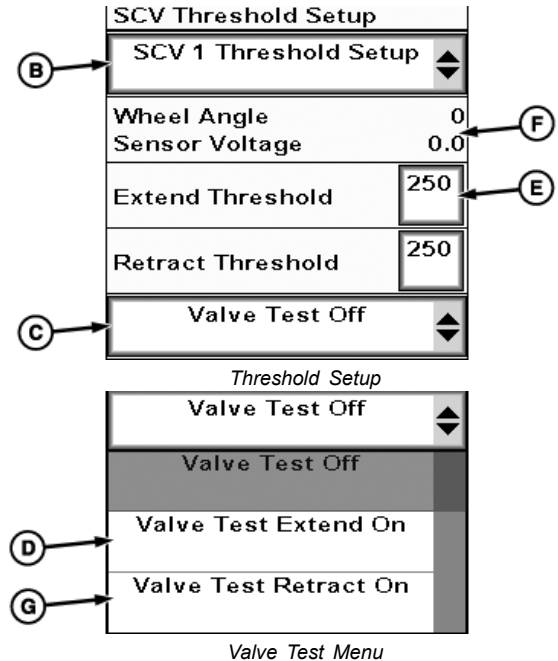

- | | |
|--------------------------------------|---------------------------------------|
| B—SCV SELECTION Button | E—EXTEND THRESHOLD Value |
| C—VALVE TEST Menu Button | F—SENSOR VOLTAGE Value |
| D—VALVE TEST EXTEND ON Button | G—VALVE TEST RETRACT ON Button |

NOTE: After calibration is complete, it is important to measure guess rows or implement performance, with implement lowered into working (ground contact) position. Verify proper performance before using Active Implement Guidance in actual field operation.

BA31779,00003FE -19-13APR12-2/2

PC12963—UN—27OCT10
PC12964—UN—27OCT10

External Valve Hydraulic Flow Adjustment

To adjust the hydraulic flow when using an external valve select the setup button.

Select External Valve Setup (A) from the setup menu.

Select the SCV that is setup for control on the Control Selection page and adjust the flow rate to desired number.

Flow rate is adjusted in percent from 10% to 100%. Flow rate is determined by the size of cylinder used to operate Active Implement Guidance.

The SCV Max Flow (%) value will be defaulted to 100. It is recommended to adjust this value to 30 when getting started. The operator may have to adjust this value up or down depending on implement performance during operation.

NOTE: When using power beyond, the hydraulic flow rate to the implement can be adjusted here.

A—External Valve Setup
B—SCV 1 Max Flow

C—SCV 3 Max Flow

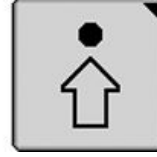

Setup Button

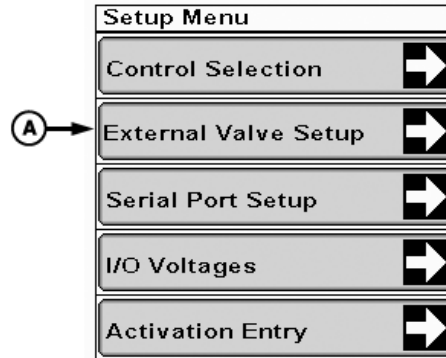

Setup Menu

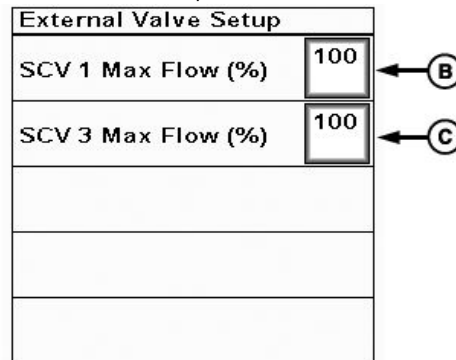

External Valve Setup

PC13786 —UN—20MAY11

PC13787 —UN—20MAY11

Requirement to Engage

Active Implement Guidance has an option to select when it is operating.

To select when Active Implement Guidance is operating:

1. Select Implement Steer Setup (A) from the main menu
2. The bottom of the Implement Steer Setup page (B) displays the requirement to engage that is selected. Press the box to change the setting.

3. The box will display what type of requirement to engage is available. Select the requirement from the box. **AutoTrac** will engage Active Implement Guidance whenever AutoTrac is enabled.

AT + Imp Switch Open will engage Active Implement Guidance whenever AutoTrac is enabled and the Implement Switch is open.

AT + Imp Switch Closed will engage Active Implement Guidance whenever AutoTrac is enabled and the Implement Switch is closed.

AT + Hitch Down will engage Active Implement Guidance whenever AutoTrac is enabled and the Hitch is down.

A— Implement Steer Setup

B— Requirement to Engage

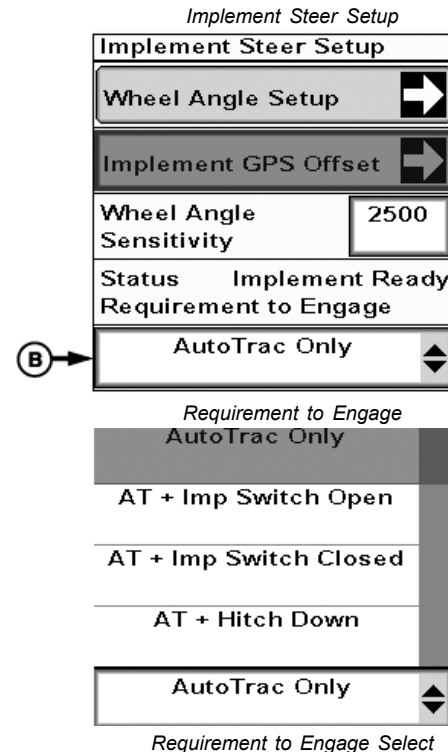
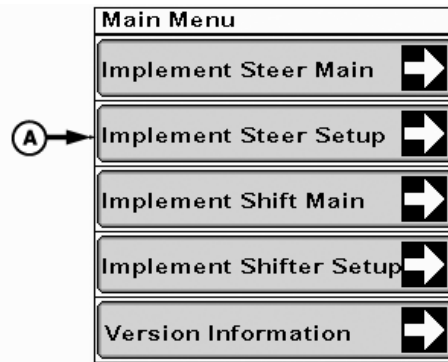

CF86321,0000380 -19-31MAY11-1/1

PC13494 —UN—03MAY11

PC13505 —UN—03MAY11

PC13506 —UN—03MAY11

External Valve

IMPORTANT: External Valve with open center must have an in-line check valve installed on the pump hose.

If using an External Valve the 9 pin Vehicle Side Implement Feedback Harness must be used for the External Valve to operate. Disconnecting this harness must be done when tractor is powered off.

In order to conserve tractor SCV connections an External Valve connection for Active Implement Guidance is available. External valve can either be connected to

an open SCV on the tractor or can use power beyond as a hydraulic power source from the tractor. External valve mounting bracket comes in a kit from John Deere. Mounting location is dependent on the implement type and correct hose and harness routing. Parts included in the kit are mounting hardware, wiring harnesses, external valve, and SCV control switch. User supplies the hoses and fittings for plumbing, depending on how and where the valve is placed.

NOTE: For more information about connecting the External Valve to power beyond, please reference Application Controller 1100 / External Valve Install Instruction.

BA31779,00003F8 -19-02MAY12-1/1

Operation

Basic Operation of Active Implement Guidance System

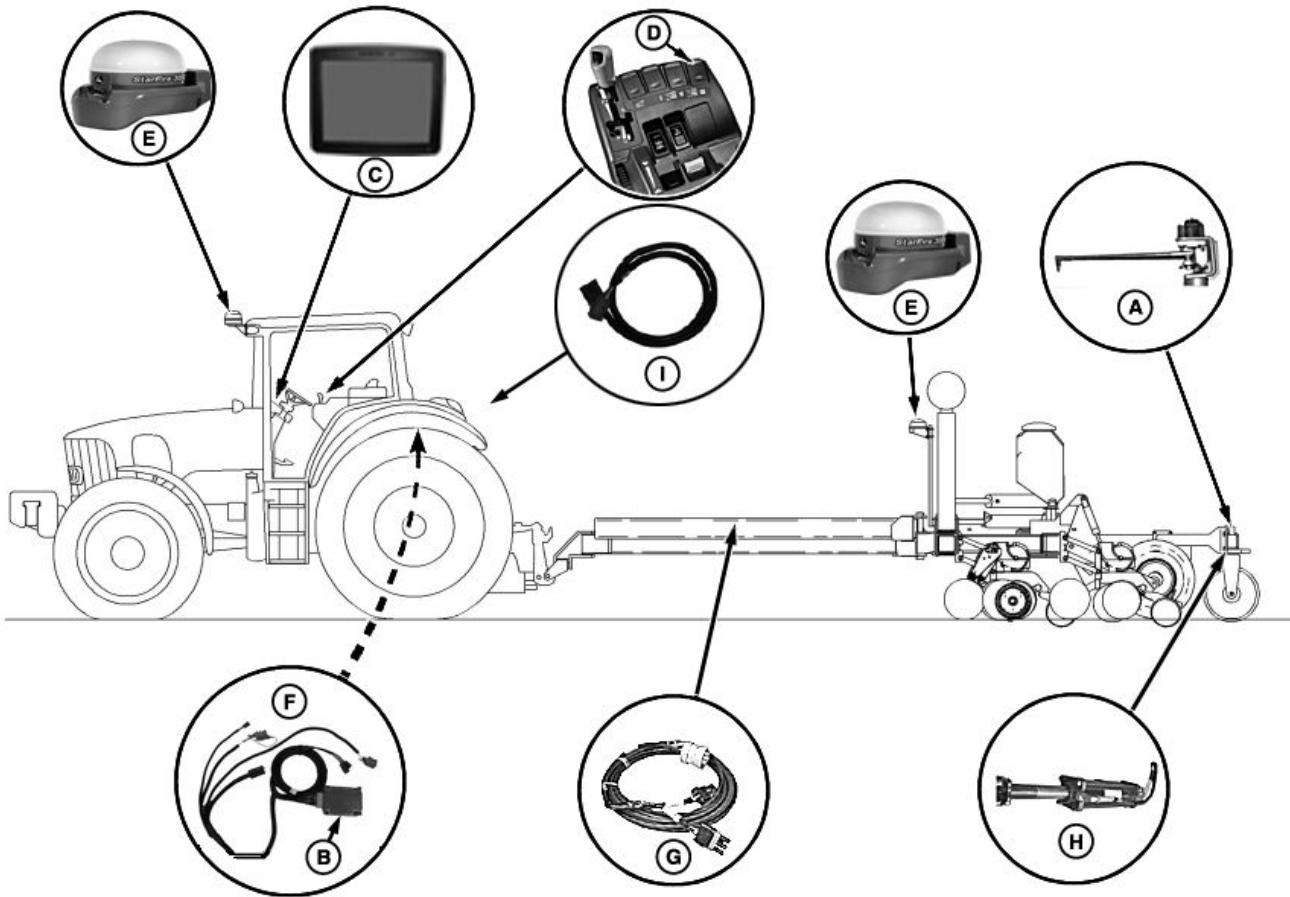

Active Implement Guidance

- | | | |
|-----------------------------------|--|--|
| A — Wheel Angle Sensor | E — StarFire RTK GPS Receivers | H — Hydraulic Steering Cylinder |
| B — Application Controller | F — Application Controller | I — 9 Pin Vehicle Side Implement Feedback Harness |
| C — Display | G — Implement Feedback Sensor Harness | |
| D — SCV Control Lever | | |

- SCV controller is set to auto (AC) mode.
- A wheel angle sensor (A) communicates the steered angle of implement to the controller (B) with signals carried through the implement feedback harness (G).
- This implement steering angle information is calibrated for the controller by the operator, using display (C) and SCV control lever (D).
- The Active Implement Guidance controller calculates an implement off-track error using location of StarFire RTK GPS receivers (E), with guidance line values set in tractor for AutoTrac.
- When AutoTrac is *enabled* and *activated*, and *if* machine requires steering adjustment to bring it back on guidance line, a signal is sent from Active Implement Guidance controller, through the Application Controller harness (F), to tractor SCV controller or external valve.

- The SCV controller communicates instructions for sending hydraulic fluid to the implement steering cylinder (H).
- This entire process returns to the first step to continually monitor for any implement off-track error. Constant adjustments are made to keep the implement steering towards the currently active guidance line.

NOTE: *Active Implement Guidance will operate in reverse for 45 seconds. After 45 seconds, AutoTrac and Active Implement Guidance will both disengage, removing their control of tractor and implement.*

PC13513 —UN—02MAY11

CF86321,0000387 -19-01JUN11-1/1

Engaging Active Implement Guidance

IMPORTANT: If the steering device is not in contact with ground, Active Implement Guidance will not be able to effectively steer the implement.

1. Set up guidance lines on GreenStar display.
2. Using SCV controls, press SCV III lever (A) to detent position to activate implement guidance.

NOTE: SCV III should only be pressed once at beginning of each field, not every pass.

3. Select SCV III button (C) on right-hand display.
4. Verify that "EC" (manual SCV control) on Right-Hand Display (D) changes to "AC" (auto SCV control).

If operating a tractor with command center, it will change from auto with a line through it (F) to auto with out a line through it (E).

NOTE: For more information on Command Center SCV controls refer to your tractors operator manual.

IMPORTANT: Active Implement Guidance will begin acquiring line immediately after AutoTrac Resume button is selected. With implements using a coultter steering system, movement will start even if implement is not in contact with the ground.

5. Press AutoTrac resume switch (B) on tractor to activate AutoTrac and Active Implement Guidance simultaneously. You should see tractor and implement both steer toward current guidance line.

NOTE: Active Implement Guidance will operate in reverse for 45 seconds. After 45 seconds, AutoTrac and Active Implement Guidance will both disengage, removing their control of tractor and implement.

- | | |
|----------------------------|--------------------------|
| A—SCV III Control Lever | D—SCV Right-Hand Display |
| B—AutoTrac Resume Switch | E—Auto Operating |
| C—SCV III Selection Button | F—Auto Not Operating |

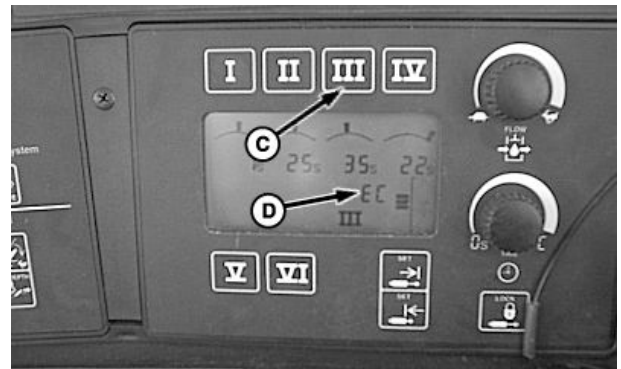

Command Center Auto SCV control

Continued on next page

BA31779.00003FF -19-13APR12-1/2

PC12212—UN—18AUG09

PC12211—UN—10SEP09

PC13540—UN—06MAY11

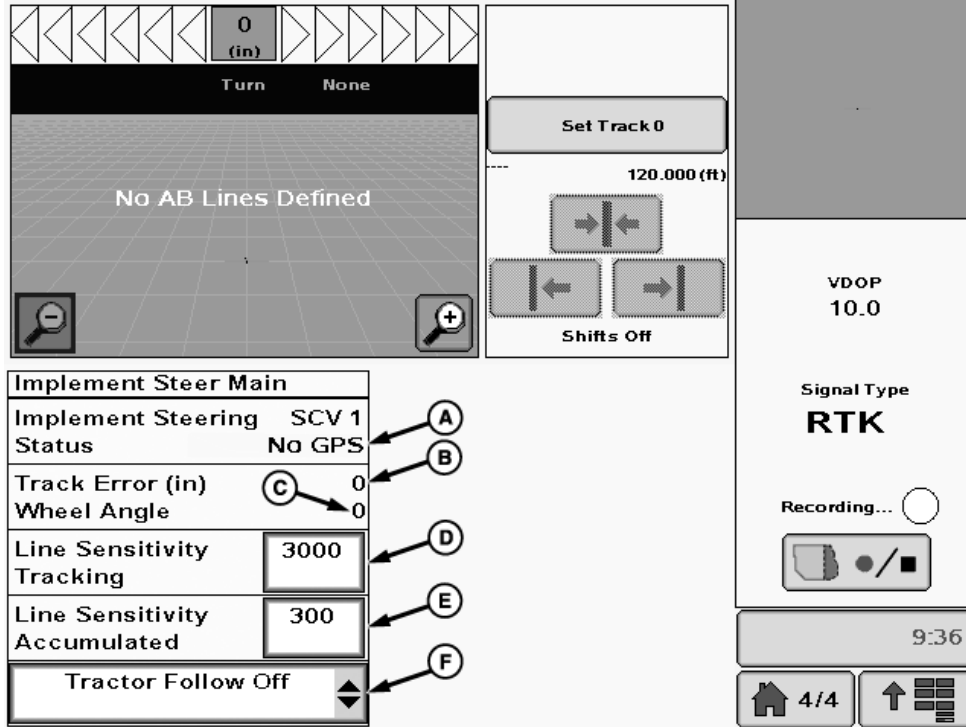

A—SCV Control Assignment and Status
 B—Off-Track Error (Distance)
 C—Wheel Angle (Implement)
 D—Line Sensitivity Tracking

E—Line Sensitivity Accumulated
 F—Tractor Follow On/Off

IMPORTANT: Illustrated display screen is for reference only. Actual screens may appear differently due to connection of optional devices and/or software version in use.

See your GreenStar display Operator's Manual for information on page layout and display adjustments.

Active Implement Guidance Display Information:

- **(A) SCV Control Assignment and Status** - SCV control type is identified along with status of that SCV. Status will alert operator to current condition of control system. Status can guide operator to any unresolved issues that prevent Active Implement Guidance operation.
- **(B) Off-Track Error (Distance)** - Distance the implement is off-track from current guidance line. A properly balanced implement will see off-track errors + and - each side of 0.
- **(C) Wheel Angle (Implement)** - Amount of corrective wheel movement to keep Off-Track Error at 0. Wheel angle will see + and - on each side of 0. A wheel angle consistently on one side or other indicates system is steering one way to shift machine. If operating in straight track mode this may indicate operation on a hillside,

- or if on flat ground, may be the result of an incorrect CENTER calibration or poor implement balance.
- **(D) Line Sensitivity — Tracking** - Line acquisition only – Determines how aggressively Active Implement Guidance responds to tracking errors while machine is acquiring the track. Tracking error is the distance between implement location and desired track. Setting this number higher will cause Active Implement Guidance to respond more aggressively to match implement location to desired track. Higher numbers will result in more aggressive line acquisitions. Lower gains may result in reduced accuracy (see IN-FIELD ADJUSTMENTS/TUNING in this section). Value Range: 10 - 10000. Default setting: 3000.
- **(E) Line Sensitivity — Accumulated** - On-line performance only – How fast or aggressively the system commands the wheels to react to off-line errors while on hills and slopes (see IN-FIELD ADJUSTMENTS/TUNING in this section). Value Range: 10 - 10000. Default setting: 300.
- **(F) Tractor Follow On/Off** - Allows the operator to turn Follow Mode On/Off

NOTE: For Follow Mode refer to page 25-5 in this operator manual.

BA31779,00003FF -19-13APR12-2/2

PC13066—UN—11NOV10

In-Field Adjustments/Tuning

With AutoTrac and Active Implement Guidance engaged in the field, line sensitivities and SCV flow rates can be fine-tuned for optimum performance.

Adjusting Sensitivity Settings:

1. **Line Sensitivity Tracking:** Line acquisition – How fast or aggressively the wheel steers towards guidance line.

Tracking value (A) is listed and adjusted at this screen. Range is 10 - 10000 with typical setting between 1500 - 5000. Increasing the setting will increase aggressiveness of the steering.

A recommended starting point is to have the Line Sensitivity Tracking about 10 times the value of the Lines Sensitivity Accumulated and then tune them individually.

2. **Line Sensitivity Accumulated:** On-line performance – How quickly the system reacts to errors while off-line on hills and slopes.

Accumulated value (B) is listed and adjusted at this screen. Range is 10 - 10000 with typical setting between 150 - 500. Increasing the setting will increase reaction speed during off-track conditions.

3. **Wheel Angle Sensitivity** Effects how aggressive the system responds to errors in command steering angle.

Adjust the value of the wheel angle sensitivity (E) to desired number. The higher the number the more aggressive the system responds to errors. Wheel angle sensitivity values range between 10-9999.

- Small Cylinder = 500
- Large Cylinder = 5000

Tuning SCV Controller Flow Rates:

1. Select SCV III on right-hand display (D).
2. Use flow adjustment dial (E) to increase SCV flow until steering mechanism is unstable.

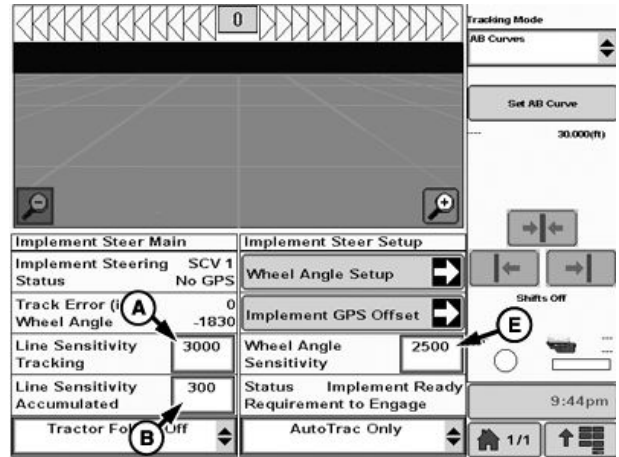

Home Screen



- A—Line Sensitivity Tracking Input
- B—Line Sensitivity Accumulated Input
- C—SCV III Selection Button
- D—Flow Adjustment Dial
- E—Wheel Angle Sensitivity

3. From this point, decrease flow until steering mechanism stabilizes.

Continued on next page

DK01672,0000178 -19-09AUG11-1/2

PC13549 —UN—03MAY11

PC13068 —UN—11NOV10

Tuning SCV Controller Flow Rates on Command Center

1. Press Detent Flow Softkey (A) to highlight flow bar graph (B)
2. Rotate Command ARM controls thumb wheel forward or rearward while watching current flow bar graph indicator (C) move right or left respectively. Value in detent flow box (D) increases and decreases as thumb wheel is rotated

NOTE: Bar Graph depicts amount of flow. Flow is displayed in increments of 0.04 beginning at 0.04 through 10 in detent flow box (D).

3. Press confirm button to set desired flow rate

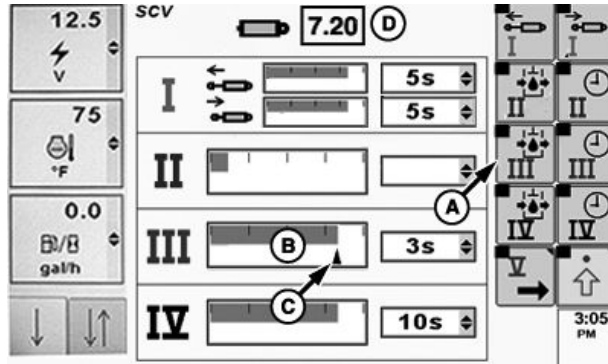

Command Center SCV Flow

- A—Detent Flow Softkey
- B—SCV Flow Graph
- C—Current Flow Bar Graph Indicator
- D—Detent Flow Box

DK01672,0000178 -19-09AUG11-2/2

PC13546 —UN—03MAY11

Follow Mode

PC13072 —UN—16NOV10

Follow Mode sets the implement guidance path in the same path as the machine receiver. This allows Active Implement Guidance to operate without a guidance line defined and while the operator is driving the machine. This is especially useful during the first pass through a field when the guidance line is being defined.

CAUTION: Do not operate Follow Mode on roadways.

NOTE: Follow Mode will turn off above 35 kph (21.7 mph)

Follow Mode will also turn off if speed drops below 0.5 kph (0.3 mph) for longer than 30 seconds.

To turn Follow Mode On/Off:

1. Select MAIN softkey
2. Select IMPLEMENT STEER MAIN (A)
3. In the Drop-Down box (B), Select either TRACTOR FOLLOW ON or OFF



Application Controller Main Softkey

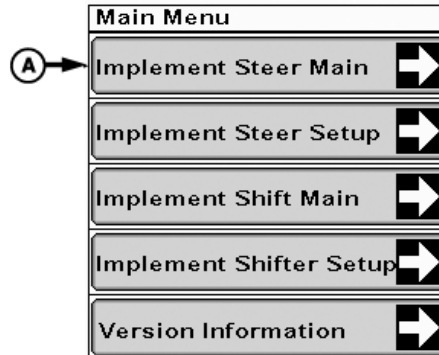

Implement Steer Main Button

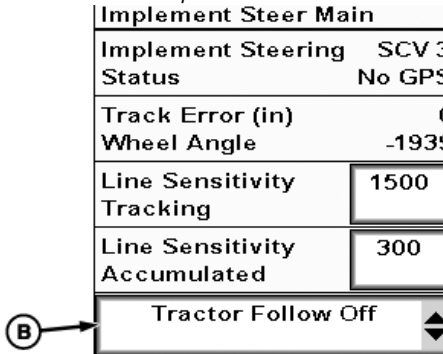

Implement Steer Main

CF86321,000038A -19-01JUN11-1/1

PC13503 —UN—03MAY11

PC12896 —UN—01NOV10

Disabling Active Implement Guidance

PC12961 —UN—29AUG11

CAUTION: Active Implement Guidance is not meant for road transport.

To prevent serious injury, disable Active Implement Guidance by removing SCV control before entering roadways.

To disable Active Implement Guidance by removing SCV control:

1. Select SETUP softkey
2. Select CONTROL SELECTION (A)
3. Set SCV1 (B) and SCV3 (C) CONTROL TYPE to OFF

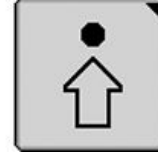

GreenStar Toolbox Setup Softkey

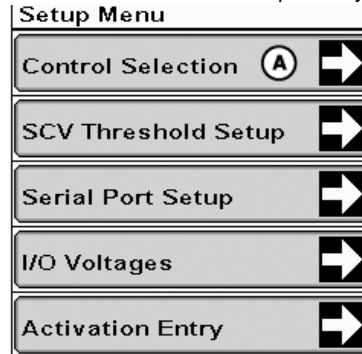

Control Selection Button

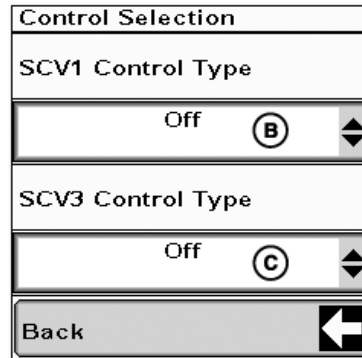

SCV Control Selection

CF86321.000038B -19-01JUN11-1/1

PC13493 —UN—03MAY11

PC13512 —UN—03MAY11

Disconnecting Active Implement Guidance

Disconnecting the Active Implement Guidance System

NOTE: If an electronic failure occurs, hydraulic control can be set to operate in normal, manual mode.

If running an external valve, operation is not possible during an electronic failure.

Without electronic control, automatic implement steering adjustments are not possible.

Disconnection Procedure for Changing Tractor or Implement:

1. Shut OFF machine, set parking brake, and remove key.
2. Disconnect implement receiver harness at ISO 9 pin connector (A).
3. Disconnect constant power harness (harness not shown).

NOTE: Once completed, tractor SCV control will revert to normal manual operation.

4. Disconnect the 9 pin feedback harness (C).
5. Disconnect lighting connector (B) and all other implement connections related to releasing equipment from tractor.

Disconnection Procedure for Electronic Failure:

- On Active Implement Guidance *Setup Menu*, select CONTROL SELECTION.
- On CONTROL SELECTION drop-down menu, select OFF.
- After OFF has been selected, cycle machine power and Active Implement Guidance will be disabled.

Disconnection Procedure for Permanent Removal:

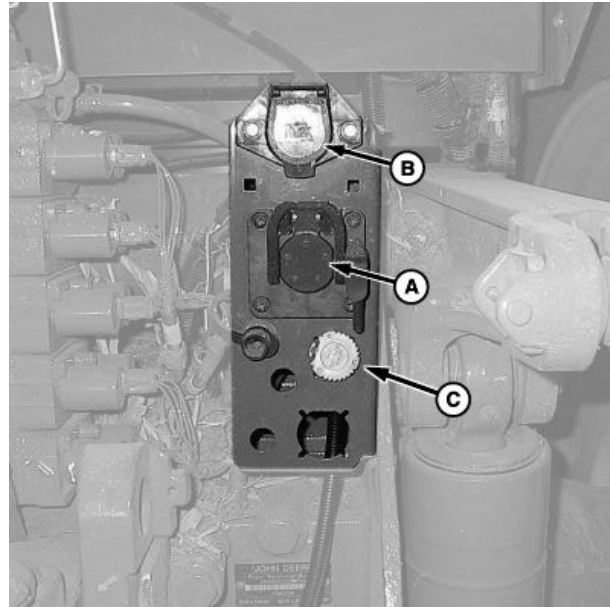

Rear of Tractor Shown

A—ISO Connector
B—Lighting Connector

C—9 Pin Feedback Harness

- Shut OFF machine, set parking brake, and remove key.
- Disconnect Active Implement Guidance controller from rear of ISO connector.
- Remove controller and components following procedures in Active Implement Guidance installation instructions.

PC13526—UN—03MAY11

BA31779,00003FA -19-13APR12-1/1

Troubleshooting

Troubleshooting — Active Implement Guidance System

Implement Steer Main	
Implement Steering	SCV 1
Status	A → No GPS
Track Error (in)	0
Wheel Angle	-1823
Line Sensitivity Tracking	3000
Line Sensitivity Accumulated	300
Tractor Follow Off	

Status Code Location

A—Status Code

Status Code	Description	Solution
No GPS	No GPS visible on system at location specified in control selection area for this SCV.	Change control selection for GPS to correct location or install GPS.
Cycle Power	Controller must be restarted to communicate with new function.	Shut OFF tractor and start again.
No RTK	No RTK correction seen on selected GPS, or RTK not currently available.	Activate RTK on implement GPS and/or machine GPS.
Update GPS SW	Incompatible software loaded.	Update software on GPS receiver(s) to compatible version.
Tractor SCV Not Auto	SCV control not detented to engage Active Implement Guidance	Detent SCV to engage Active Implement Guidance. For external valve detent the added SCV lever.
OK	System is ready to be operated. Any faults still occurring are likely to be independent of Active Implement Guidance control system and on tractor or implement.	System is working properly.

Symptom

Monitor Screen not Readable on hookup to Machine

Problem

No communications with implement controller.

Solution

Shut OFF power, check connections, and power up to reboot system.

Check 4 pin DEUTSCH connector at back of ISO implement connector on tractor for cleanliness and proper attachment.

Verify connector at head of implement is seated and tight.

CF86321,0000346 -19-23MAY11-1/1

PC13527—UN—03MAY11

Troubleshooting — Machine

Symptom	Problem	Solution
AC (Auto Control) not showing on SCV Display	Dirty or loose 10-pin connector at rear of tractor.	Clean connectors and reconnect tightly. Verify correct control type and SCV are selected in Active Implement Guidance setup and power has been cycled.
	Implement Steers Away from Line when AutoTrac Resume Button is Pressed	SCV hoses hooked up in reverse. Implement steering calibration was done with right and left limits reversed.
Machine not Steering to Line	EC displayed on SCV display.	Push correct SCV control lever into detent to bring up AC mode.
Hydraulic Steering not Responding Well	Steering cylinder leaking fluid.	Check for leakage (see SERVICE SECTION in this manual). Repair or replace cylinder (see your John Deere dealer).
	Insufficient tractor hydraulic pressure.	Check tractor hydraulic pressure (see tractor Operator's Manual for reference). Ensure hydraulic oil is warmed up. Use correct size hydraulic cylinders for tractor pressure.
	Hydraulic hoses connected improperly or poorly.	Check hose O-rings, connect properly and tighten connections.
	Valve is frozen.	Cycle hydraulic cylinders manually, to the full right and left. If condition repeats, oil may be contaminated causing plugging or SCV may require a shuttle valve to prevent it from going into Desilting Mode during low flow conditions.
Loss of Display and Operation of Implement	Dirty or loose 4-pin connection at rear of tractor.	Clean connectors and reconnect tightly.
	GreenStar harness improperly connected.	Disconnect harness, clean, and install properly.
	Electrical short in harness.	Check electrical wiring for breaks, shorts, and damage.

CF86321,0000347 -19-31MAY11-1/1

Troubleshooting — Active Implement Guidance External Valve

Cannot get External Valve to function properly.

1. Make sure Implement Steering is selected for SCV1.
2. Select the settings button (arrow and dot); is there a button that reads “External Valve Setup” or “SCV Threshold Setup”?
If it shows “SCV Threshold Setup” then the controller is not recognizing the external valve is installed.
3. In the Message Center under the Controllers menu, make sure there is controller address 0x81 (valve address). If not, troubleshoot the implement CAN bus - if the implement receiver does not show up on the screen there is likely a CAN bus problem. There is an LED on the valve that is on if the valve is powered and it claims address 0x81 if the CAN is working properly.
4. Check the I/O Voltages page. Make sure the “Sense Volt” reads close to zero. If it reads around to 5 V, then it means RE58827 harness is plugged in and needs to be removed (turn off tractor before unplugging harness). This harness (RE58827) tells the controller the external valve is on a tractor with integrated valves and the external SCV control lever does not work. In this case “External Valve Setup” button is not present.
5. Watch the “Digital 1” line. If the external valve controller (the extra SCV lever) is centered (and not touching it), the value should be 1 and when moved

off center it should be 0. If that is not happening, then confirm connections between harnesses PFP10967 and PFP10852. Make sure that it is plugged into the controller harness and not the implement receiver or front extension harness (the same connector is used both places). Check that pins are not backed out.

6. Check the color of the LED on the Valve. The LED has three colors:
 - Red - Internal error on valve software.
 - Orange - Valve is NOT receiving a command to move or command is zero.
 - Green - Controller is commanding valve to move.

⚠ CAUTION: If system starts working implement could move.

7. The LED is red if the hydraulic pressure is hooked up backwards or if there is back pressure on the left/right ports. To release back pressure put tractor hydraulics in float, and then cycle external SCV control lever. A power cycle is required to clear the error on the valve. If that does not release the pressure on the work ports then it must be relieved manually by putting the tractor hydraulics in float and relieve pressure by moving the external valve spool with the supplied handle.

⚠ CAUTION: Hydraulics can move when handle is moved.

BA31779,0000505 -19-18SEP12-1/1

Service

Active Implement Guidance System

Being an electronic controller, there is minimal service required to maintain performance levels. However, the John Deere AMS commitment to continued improvement and quality may lead to periodical software updates available for this controller. To maintain optimum performance, these updates should be loaded.

For the GS2/GS3 system this is accomplished when you perform a "live update" using a connection to the StellarSupport™ website (www.stellarsupport.com). Updates, once downloaded must be loaded onto your CompactFlash for GS2 or USB memory device (A) for GS3. After updating the memory device, the next time you insert the Compact Flash or USB memory device into your display console (B) the operating system will prompt you that updates are available. Accepting the updates will automatically update your Active Implement Guidance system to the most recent version.



GS3 2630

A— USB Memory Device

B— GS3 2630 Console

PC13504—UN—28APR11

StellarSupport is a trademark of Deere & Company

CF86321,0000348 -19-23MAY11-1/1

Machine

Refer to manufacturer of implement steering module for servicing procedures.

CF86321,0000349 -19-23MAY11-1/1

EC Declaration of Conformity

**Deere & Company
Moline, Illinois U.S.A.**

The person named below declares that

Product: Active Implement Guidance

Fulfills all relevant provisions and essential requirements of the following directives:

Directive	Number	Certification Method
Electromagnetic Compatibility Directive	2004/108/EC	Annex II of the Directive

Name and address of the person in the European Community authorized to compile the technical construction file:

Brigitte Birk
Deere & Company European Office
John Deere Strasse 70
Mannheim, Germany D68163
EUConformity@johndeere.com

Place of declaration: Kaiserslautern, Germany

Date of declaration: 18 May 2011

Manufacturing unit: John Deere Intelligent Solutions Group

Name: Aaron Senneff

Title: Engineering Manager, John Deere Intelligent Solutions Group

Intelligent Solutions Group

DXCE01—UN—28APR09



DK01672,0000163 -19-05AUG11-1/1

Index

	Page		Page
A			
Active Implement Guidance			
Basic operation	25-1	Follow Mode	25-5
Component locations	25-1	Functional requirements	10-3
Components	25-1	G	
Control system	15-1	GPS receiver	15-1
Disabling	25-6	H	
Disconnecting the system	30-1	Hardware	10-1
Functional requirements	10-3	I	
GS2 Display	15-3	Implement controller	15-4
Hardware	10-1	M	
Implement steering calibration	20-4	Machine compatibility	10-3
Machine compatibility	10-3	Machine service	40-1
Machine service	40-1	Machine troubleshooting	35-2
Monitor	15-1	Monitor	15-1
Replacing eproms	10-3	O	
SCV control assignments	20-3	Operating requirements	10-3
Service	40-1	R	
Setup requirements	20-1	Receivers	
Software and settings	10-1	StarFire	15-1
StarFire receivers	15-1	Replacing eproms	10-3
Theory of operation	10-1	Requirement to Engage	20-8
Troubleshooting		S	
Machine	35-2	Safety, Avoid High-Pressure Fluids	
Status codes	35-1	Avoid High-Pressure Fluids	05-3
System	35-1	SCV control assignments	20-3
Active Implement Guidance calibration	20-4	Service	
Adjustments in the field	25-4	Active Implement Guidance system	40-1
Assign SCV controls	20-3	Machine	40-1
C		Setup requirements	20-1
Command Center		Shared Signal	15-2
SCV Flow Rate	25-5	Software and settings	10-1
Component locations	25-1	StarFire receivers	15-1
Component operations	25-1	Status code troubleshooting	35-1
Control system	15-1	Steering calibration	20-4
Implement controller	15-4	System troubleshooting	35-1
Wheel angle sensors	15-5	T	
Controller		Theory of Operation	10-1
Upgrading	10-3		
D			
Disabling Active Implement Guidance	25-6		
Disconnecting Active Implement Guidance system	30-1		
Display	15-3		
E			
External Valve	20-8		
Hydraulic Flow Adjustment	20-7		
Machine Compatibility	10-3		

Continued on next page

	Page
Troubleshooting	
Active Implement Guidance status codes.....	35-1
Active Implement Guidance system.....	35-1
Machine	35-2
Tuning in the field	25-4

U

Upgrading controller	10-3
----------------------------	------

W

Wheel angle sensors.....	15-5
--------------------------	------

John Deere Service Literature Available

Technical Information

Technical information can be purchased from John Deere. Some of this information is available in electronic media, such as CD-ROM disks, and in printed form. There are many ways to order. Contact your John Deere dealer. Call **1-800-522-7448** to order using a credit card. Search online from <http://www.JohnDeere.com>. Please have available the model number, serial number, and name of the product.

Available information includes:

- **PARTS CATALOGS** list service parts available for your machine with exploded view illustrations to help you identify the correct parts. It is also useful in assembling and disassembling.
- **OPERATOR'S MANUALS** providing safety, operating, maintenance, and service information. These manuals and safety signs on your machine may also be available in other languages.
- **OPERATOR'S VIDEO TAPES** showing highlights of safety, operating, maintenance, and service information. These tapes may be available in multiple languages and formats.
- **TECHNICAL MANUALS** outlining service information for your machine. Included are specifications, illustrated assembly and disassembly procedures, hydraulic oil flow diagrams, and wiring diagrams. Some products have separate manuals for repair and diagnostic information. Some components, such as engines, are available in separate component technical manuals
- **FUNDAMENTAL MANUALS** detailing basic information regardless of manufacturer:
 - Agricultural Primer series covers technology in farming and ranching, featuring subjects like computers, the Internet, and precision farming.
 - Farm Business Management series examines "real-world" problems and offers practical solutions in the areas of marketing, financing, equipment selection, and compliance.
 - Fundamentals of Services manuals show you how to repair and maintain off-road equipment.
 - Fundamentals of Machine Operation manuals explain machine capacities and adjustments, how to improve machine performance, and how to eliminate unnecessary field operations.



TS189 —UN—17JAN89



TS191 —UN—02DEC88



TS224 —UN—17JAN89



TS1663 —UN—10OCT87

DX.SERVLIT -19-31JUL03-1/1

John Deere Service Keeps You on The Job

John Deere Is At Your Service

CUSTOMER SATISFACTION is important to John Deere.

Our dealers strive to provide you with prompt, efficient parts and service:

- Maintenance and service parts to support your equipment.
- Trained service technicians and the necessary diagnostic and repair tools to service your equipment.



CUSTOMER SATISFACTION PROBLEM RESOLUTION PROCESS

Your John Deere dealer is dedicated to supporting your equipment and resolving any problem you may experience.

1. When contacting your dealer, be prepared with the following information:

- Machine model and product identification number
- Date of purchase
- Nature of problem

2. Discuss problem with dealer service manager.

3. If unable to resolve, explain problem to dealership manager and request assistance.

4. If you have a persistent problem your dealership is unable to resolve, ask your dealer to contact John Deere for assistance. Or contact the Ag Customer Assistance Center at 1-866-99DEERE (866-993-3373) or e-mail us at www.deere.com/en_US/ag/contactus/.

DX,IBC,2 -19-02APR02-1/1

TS201 —UN—23AUG88

